



MAGNA SPARK II™ DISTRIBUTOR



- Easy 2-wire installation with no external spark box necessary, but can be used with one.
- Precision CNC machining and hand assembled construction. This is a premium product.
- Accurate super hot spark all the way through 10,000 RPM.
- Hardened steel .500" diameter shaft with sealed quality roller bearing upper support and bronze bushed lower support for extreme stability at maximum RPM.
- Powerful magnetic pickup and CNC machined reluctor pickup.
- Fully adjustable advance mechanism with easy to use spring and bushing design for a nearly infinite advance curve.
- MAGNASPARK II™ module built in for drop-in reliability from 50 to 10,000 RPM.
- High quality injection molded caps with brass terminals for long life and conductivity.

Please read this entire brochure prior to installing your CB Performance Products MAGNASPARK II™ distributor.

cbperformance.com

MAGNASPARK II™ Installation Instructions:

Warning: Before installing the CB Performance MAGNASPARK II™

Distributor, disconnect the negative battery cable.

Preparing Your Advance Curve

Your timing curve consists of: Initial Advance, Centrifugal Advance.

Initial Advance: Often referred to as "Base Timing", this is the initial timing set to the engine at idle.

Centrifugal Advance: Often referred to as "Mechanical Advance" consists of a mechanism of weights, springs, cams and an advance stop bushing. As the engine RPM increases, the weights move creating advance. The springs determine the rate of this advance and the advance stop bushing limits the total amount of centrifugal advance.

Total Advance: This is the sum of initial advance and centrifugal advance. Example - Initial advance of 10° plus centrifugal advance of 20° = 30° of Total Advance.

Checking Total Advance and Rate of Advance: With a timing light, you can determine the total advance and rate of advance. A degreed crank shaft pulley is required for this procedure. First, start the engine and set the idle speed. Using a timing light, rotate the MAGNASPARK II™ distributor until you reach your desired base timing (degrees of timing at idle). You may need to adjust the idle speed after setting base timing. Next, rev the engine until the timing stops advancing; this will be the total advance. The RPM at which the timing stops advancing is the rate of advance. If desired, change the advance springs and/or stop bushings to adjust total and rate of advance.

Setting Centrifugal Advance

The mechanical advance uses tension springs to control the rate of advance as RPM increases, the advance stop bushing determines the amount of total advance the distributor will have. Your MAGNASPARK II™ Distributor has three sets of advance tension springs and four different advance stop bushings included.

Changing the Advance Springs:

You can mix or match the springs for your advance rate. Your distributor has 3 sets of springs of which one set (Light Silver) is installed. The other 2 sets are in the parts kit and consist of a Heavy Silver Set and Blue set. The strongest to weakest spring ratings are as follows:

Strong Rate = Heavy Silver
 Medium Rate = Light Silver
 Light Rate = Blue

Caution: Use eye protection when changing advance springs.

1. Remove your distributor cap and rotor.
2. Carefully use needle-nose pliers to pull the spring and lift it off one of its posts. With one end of the spring off, the other end will now freely lift off its post.
3. Place desired spring on its inner post making sure it is seated in its receiver groove.
4. With your needle-nose pliers pull spring over its outer post making sure to secure this end in its receiver groove.

Parts List

- (1) MAGNASPARK II™ Distributor
- (1) Advance Kit
- (1) O-Ring
- (1) Instruction Manual

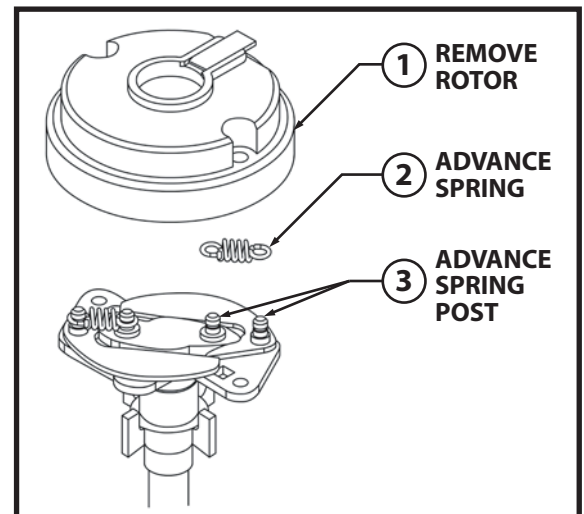
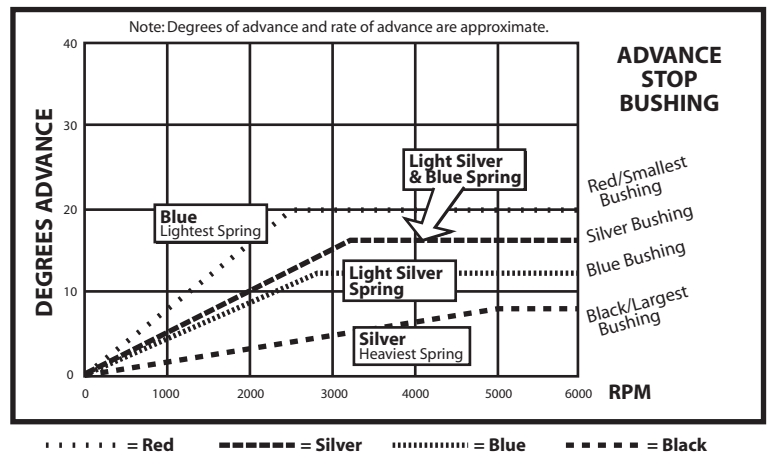

Spring Combination

Spring Combination	Rate of Advance
Heavy Silver + Heavy Silver	Slowest (@ ~5500 RPM)*
Heavy Silver + Light Silver	(@ ~4600 RPM)*
Heavy Silver + Blue	(@ ~4000 RPM)*
Light Silver + Light Silver	(@ ~3200 RPM)*
Light Silver + Blue	(@ ~2800 RPM)*
Blue + Blue	Fastest (@ ~2500 RPM)*

(NOTE: Advanced Rate RPM's are approximate.)

***Verify with timing light**

Changing the Advance Stop Bushing:

The advance stop bushings are of different outer diameters. The smaller the diameter, the more advance it allows. The advance bushings are also color coded for ease of identification. A 'Red' advance stop bushing is pre-installed in your distributor and the parts kit will have 3 additional bushings.

Bushing Color	Approx. Max. Advance in Crankshaft Degrees
Red (smallest)	20 degrees
Silver	16 degrees
Blue	12 degrees
Black (largest)	8 degrees

1. Remove your distributor cap.
 2. Using a 7mm wrench remove the locknut and flat washer from the bottom of the mechanical advance plate.
 3. Remove the bushing and install the desired bushing.
 4. Re-install the washer and the locknut, making sure the locknut is tight.
- Note:** You may want to turn the distributor upside down to ease in the installation of the advance stop bushing if the distributor is removed from the vehicle.

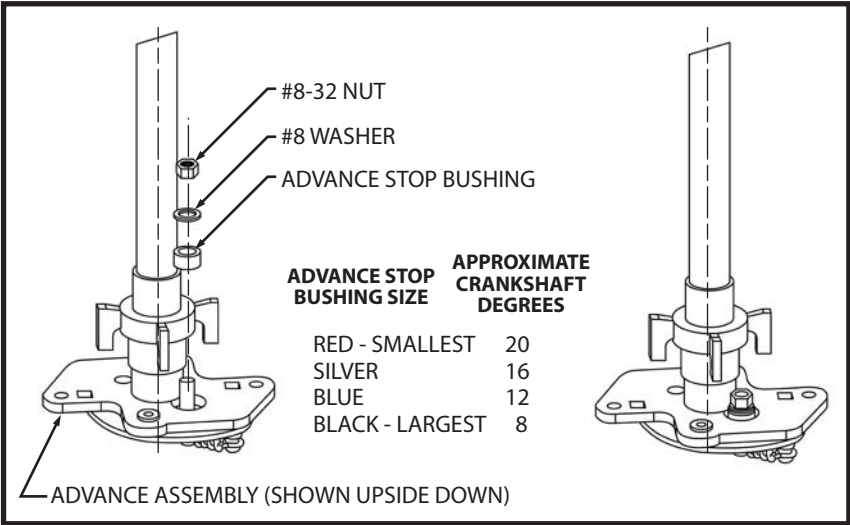

Locking out Centrifugal Advance:

If you do not want to have any centrifugal advance, you can lock it out by following this procedure with the distributor removed:

1. Remove the distributor drive gear, retaining spring clip, and roll-pin.
2. Remove the distributor gear and thrust washers.
3. With distributor gear removed, push distributor shaft approximately 2 inches out of housing.
4. Remove locknut, washer, and advance stop bushing. (***NOTE: Advance stop bushing, springs, and weights will not be used for this application.**)
5. Rotate distributor shaft 180°.
6. Align advance stop bushing stud with hole in the mechanical advance plate. Push the distributor shaft back into the housing, making sure the advance stop bushing stud goes through the hole.
7. Re-install just the washer and locknut onto the advance stop bushing stud and make sure the locknut is tight.
8. Re-install distributor thrust washers, drive gear and roll pin. Make sure retaining spring clip is re-installed.

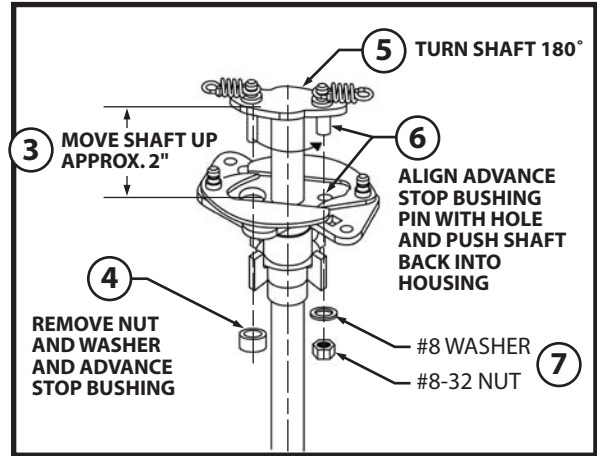
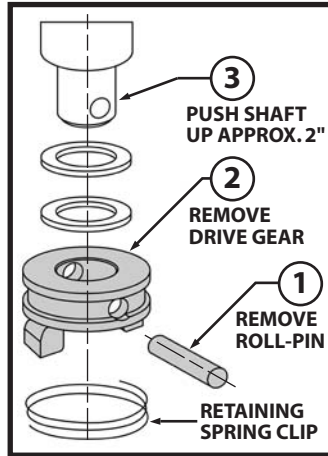

Install Distributor and Spark Plug Wires

1. Slide distributor clamp over shaft of distributor.
2. Install "O" ring on distributor.
3. With distributor cap removed, install the distributor making sure it is seated. Secure distributor clamp to engine case stud. Rotate the distributor so the rotor tip lines up with #1 terminal on cap. Tighten distributor clamp.
4. Install distributor cap and tighten securely.
5. Install Spark Plug wires, making sure firing order is correct. (*see figure 1)
6. Connect MAGNASPARK II™ Distributor wire harness to ignition coil as shown in the diagrams below.
7. Start engine and set desired timing with timing light. (See Page 1 "Check Total Advance and Rate of Advance" Section.)

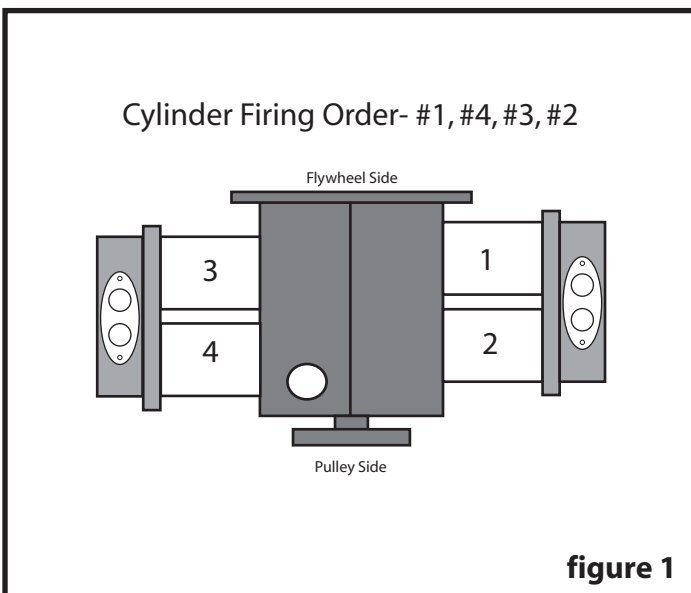
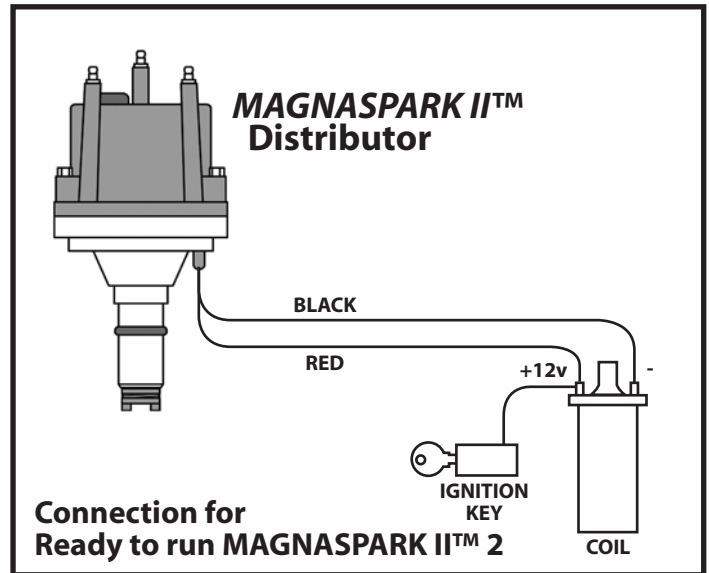
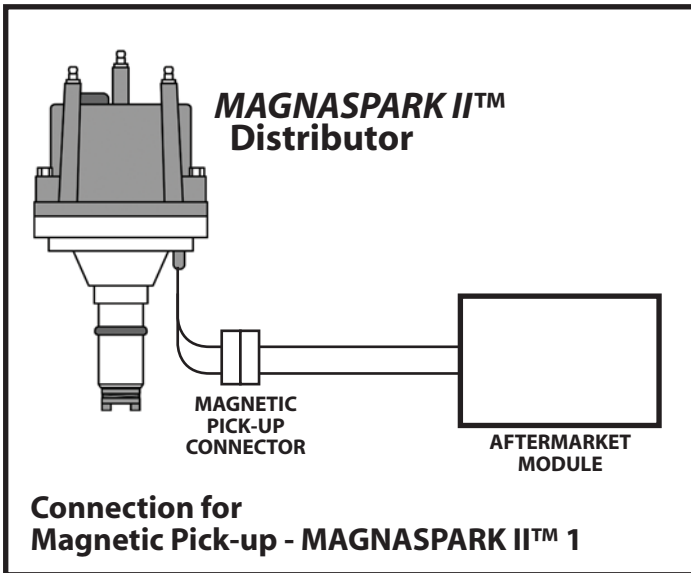

Attaching wires backwards on coil will result in immediate failure of MAGNASPARK II™ Ignition Module. Damage to MAGNASPARK II™ ignition module due to improper installation will void warranty

**** See Warranty Disclaimer on Page 4 ****

LIMITED WARRANTY

THIS IS A LIMITED WARRANTY - CB Performance Products offers a 12 month limited warranty from date of purchase on all products in the MAGNASPARK II™ line. Certain component parts of the MAGNASPARK II™ kits are limited to a 90 day warranty. Those parts are as follows: Ignition modules, and magnetic pick-ups. CB Performance Products warrants to the original purchaser of the product that the product and it's component parts will be free of defects in material or workmanship for a period of 12 months or 90 days on listed components. This warranty does not apply to products that have been (a) modified or altered in any way; (b) subjected to adverse conditions such as misuse, neglect, accident, improper installation or adjustment, dirt or other contaminants, water, corrosion, or faulty repair; or (c) used in applications other than those recommended by CB Performance Products. CB Performance Products also does not warrant, and disclaims all liability, for products used in racing activities and/or applications other than those specifically recommended in the current CB Performance Products Catalog or website. This Limited Warranty is extended to the original purchaser only and is not assignable or otherwise transferable. There are no warranties which extend beyond those stated herein. CB Performance Products offers no warranties, either express or implied, beyond this Limited Warranty. In the event of an alleged defect in material or workmanship, CB Performance Products' responsibility is strictly limited to repair or replace the defective product. CB Performance Products has no other obligation either express or implied. Final warranty determination will be at the sole discretion of CB Performance Products. CB Performance Products will not be responsible for: (a) actual or alleged labor, transportation or other incidental charges; or (b) actual or alleged consequential or other damages incurred by use of any product of CB Performance Products.

How to Initiate the Warranty Process

To initiate a warranty, your MAGNASPARK II™ product will need to be returned to place of purchase. The original purchaser will need to call CB Performance Products Warranty Center at 559-733-8222. If it is determined that the product must be returned for inspection and evaluation, you will be given an RMA (returned merchandise authorization) number. This number must be visible on the outside of the return package. Merchandise must be returned prepaid (with a copy of the original sales receipt) and insured. Also include your name, address, phone number, and a complete explanation of the problem. The product must be properly packaged so that no damage occurs in shipment. Ship product to:

CB Performance Products - 1715 N. Farmersville Blvd. - Farmersville, CA 93223

This warranty sets forth specific legal rights. The consumer may have other rights as a result of variations in state or provincial laws. This Limited Warranty supersedes all prior warranty statements.

MAGNASPARK II™ is a product of CB Performance Products, 1715 N. Farmersville Blvd., Farmersville, CA 93223

NOTES



CB Performance Products Inc. - 1715 N. Farmersville Blvd., Farmersville, CA 93223
Phone: 559-733-8222 - Fax: 559-733-7967 - www.cbperformance.com